



MAXIVAREM LR ce

**RISCALDAMENTO  
HEATING SYSTEMS**

Modello/Model: UR250471CS000000

**Caratteristiche tecniche - technical features**



Volume Volume		<b>250 L</b>
raccordo connector		<b>1" 1/2 GAS (ISO 228/1)</b>
temperatura esercizio working temperature	<b>TS</b>	<b>-10 +99 °C</b>
pressione max. Max pressure	<b>PS</b>	<b>6 bar</b>
pressione prova test pressure	<b>PT</b>	<b>9 bar</b>
precarica precharged pressure		<b>1,5 bar</b>
Fluido Fluid		<b>Aria+acqua Air+water</b>
Ente notificato per certificazione PED Notified Body number:		<b>0948</b>
Modulo: Module:		<b>B+D</b>
N° certificato N° certificate:		<b>PED-0948-QSD/D1-347-11 + TIS-PED-VI-11-02-003769-4638</b>

**Imballo - packaging**

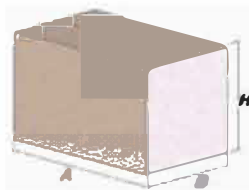
	A	B	H
dimensioni (mm) dimensions (mm)	<b>1023</b>	<b>648</b>	<b>638</b>
volume (m <sup>3</sup> ) volume (m <sup>3</sup> )	<b>0,42</b>		
peso (kg) weight (kg)	<b>44,4</b>		
q.ta per cartone q.ty for box	<b>1</b>		
quantità per paletta Q.y for std. pallet	<b>4</b>		



**Parti di ricambio - Spare parts**

	codice item	materiale material	potabilità potable	trattamento treatment	immagine image
Membrana Membrane	<b>MB200S4H000000 00</b>	<b>GOMMA EPDM NON POTABILE - NOT POTABLE EPDM RUBBER</b>			
Controflangia Coverflange	<b>SPCFL254ZN4000 00</b>	<b>ACCIAIO AL CARBONIO / CARBON STEEL</b>			
Valvola precarica Precharge valve	<b>ACVAL200PR000 000</b>	<b>OTTONE / BRASS</b>			

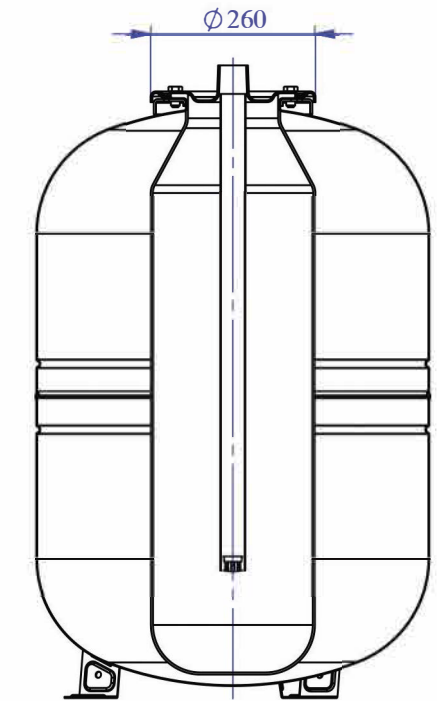
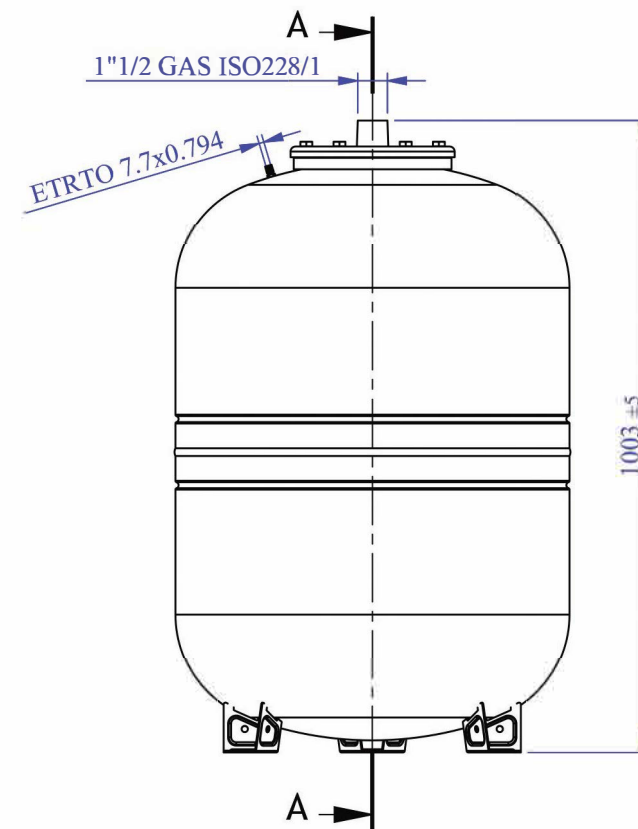
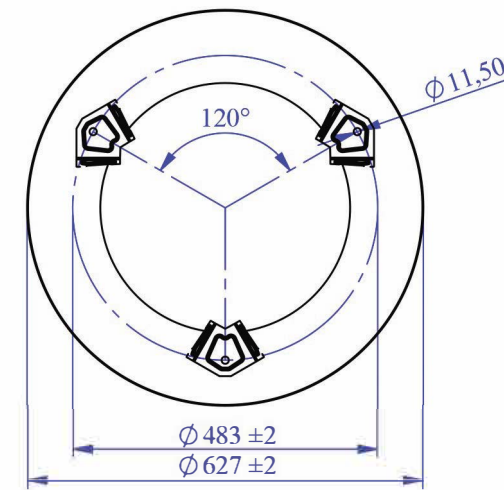

SEZIONE A-A

Quote senza indicazione di tolleranza: grado di precisione MEDIO, UNI EN 22768-1		LIPRO <b>042</b>	TIPO PARTE	COLORE <b>ROSSO / RED</b>
SMUSSI NON QUOTATI	RIGOSITÀ	QUANTITÀ PER GRUPPO	FORMATO FOGLIO <b>A3</b>	FINITURA SUPERFICIALE <b>-</b>
	SCALA <b>1:12</b>	FOGLIO <b>1 / 2</b>	Disegnato	NOME <b>M. Tomasin</b>
DESCRIZIONE <b>MAXIVAREM LR CE 250 SBR R.6/4"</b>		GRUPPO - MACCHINA	Approvato	DATA <b>25/06/2009</b>
COMMESSA <b>-</b>	CODICE <b>UR250471CS000000</b>	REVISIONE <b>00</b>		

Il presente disegno è di proprietà della **Suprex** non può essere riprodotto ne comunicato a terzi senza ns autorizzazione scritta